

Fast, Compact, High Strength Magnetic Pulse Generator

Final Report

Team Number: sdmay22-39

Advisors: Robert Bouda, Mani Mina, and Wei Shen Theh

Team Members:

Abdulraheem Alquinas

Mohd Harith Arsyad

Tyler Bolton

James Camp

Ben Newell

Tom Zaborowski

<http://sdmay22-39.sd.ece.iastate.edu/>

Revised: 28 April 2022

Executive Summary

Development Standards & Practices Used

IEEE 370-2020 - IEEE Standard for Electrical Characterization of Printed Circuit Board and Related Interconnects at Frequencies up to 50 GHz

IEEE C95.1-2019 - IEEE Standard for Safety Levels with Respect to Human Exposure to Electric, Magnetic, and Electromagnetic Fields, 0 Hz to 300 GHz

Summary of Requirements

Design and Create a Device that does the following:

- Generates Magnetic Fields of 500 Gauss at minimum
- Pulses with rise time of less than 100 ns
- Programmable Control of the magnetic field generation
- Uses a source voltage of 15 V (DC)
- Size of the circuit board is no greater than 3.5" by 2"

Applicable Courses from Iowa State University Curriculum

- E E 201: Electrical Circuits
- E E 230: Electronic Circuits and Systems
- E E 311: Electromagnetic Fields and Waves
- E E 330: Integrated Electronics
- EE 333: Electronic Systems Design
- E E 414: Microwave Engineering
- E E 417: Electromagnetic Radiation, Antennas, and Propagation

New Skills/Knowledge acquired that was not taught in courses

- Component Procurement
- Client Relations
- Coil Designing
- Perfboarding
- PCB Designing/Soldering

Table of Contents

Executive Summary	2
Development Standards & Practices Used	2
Summary of Requirements	2
Applicable Courses from Iowa State University Curriculum	2
New Skills/Knowledge acquired that was not taught in courses	2
Table of Contents	3
1 Team	5
1.1 Team Members	5
1.2 Required Skill Sets for Your Project	5
1.3 Skill Sets covered by the Team	5
1.4 Project Management Style Adopted by the team	6
2 Introduction	7
2.1 Problem Statement	7
2.2 Requirements & Constraints	8
2.3 Engineering Standards	8
2.4 Intended Users and Applications	9
3 Design	10
3.1 Summary	10
3.2 Design Considerations	11
3.2.1 Coil Characteristics	11
3.2.2 Capacitor Bank	11
3.2.3 MOSFET Considerations	12
3.2.4 Filter Design	13
3.2.5 Monophasic or Biphasic	13

3.2.6 Zero Voltage Switching	13
3.3 Prior Work	14
3.4 Basic Design	14
3.5 Zero Voltage Switching Design	15
3.6 Biphasic Design	16
3.7 PCB Design	17
3.7.1 Basic Design PCB	18
3.7.2 Monophasic Zero Voltage Switching PCB	19
3.7.3 Biphasic with Zero Voltage Switching PCB	20
4 Testing	21
4.1 Introduction	21
4.2 Testing Results	21
4.2.1 Basic Design	21
4.2.2 Monophasic ZVS Design	27
4.2.3 Biphasic Design	30
4.3 Common Issues	31
4.3.1 Breadboard	31
4.3.2 Power Supply	31
4.3.3 Oscilloscope Interference	32
5 Closing Material	33
Conclusion	33
Further Work	33
References	34
Appendix	35
Appendix I: Operation Manual (Testing Procedure)	35
Appendix II: Bill of Materials	38

1 Team

1.1 Team Members

- Abdulraheem Alqunais
- Harith Arsyad
- Tyler Bolton
- James Camp
- Ben Newell
- Tom Zaborowski

1.2 Required Skill Sets for Your Project

- Circuit Design via Multisim
- Circuit Design Optimization
- Circuit Breadboarding
- Circuit Testing
- PCB Design
- Soldering Expertise

1.3 Skill Sets covered by the Team

- Circuit Design via Multisim
 - All team members
- Circuit Design Optimization via ADS
 - James Camp
 - Ben Newell
- Circuit Breadboarding
 - All team members
- Circuit Testing
 - All team members
- PCB Designing
 - Tyler Bolton
- PCB Testing
 - All team members
- Soldering Expertise
 - All team members

1.4 Project Management Style Adopted by the team

The team adopted the Agile project management style for this project.

- Meeting Facilitator
 - Tom Zaborowski
- Circuit Testing Lead
 - Mohd Harith Arsyad
- Circuit Simulation Lead
 - Abdulraheem Alqunais
- Communications & ADS Testing Lead
 - Ben Newell
- ADS Testing
 - James Camp
- PCB Design Lead
 - Tyler Bolton

2 Introduction

2.1 Problem Statement

The goal of this project is to design and fabricate a device in a small package capable of producing high strength, fast magnetic field pulses. The device will be capable of producing magnetic field pulses greater than or equal to 500 gauss within 100 nanoseconds, will be powered by a source voltage of less than or equal to 15 Volts DC, and will be less than 3.5" by 2" in physical size. Given the design requirements and resources from the previous iterations of this project, we plan to create an improved design including a reduced rise time, functional programmable control of the magnetic field generation, reduced overall noise, and increased stability.

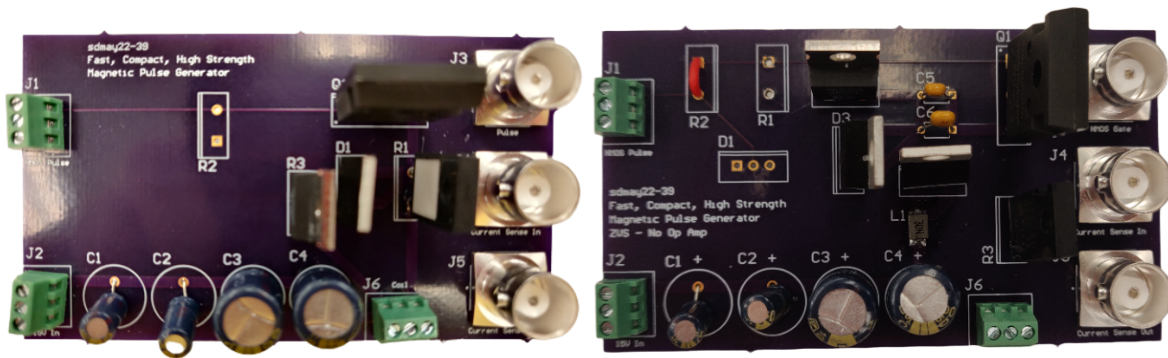

Basic Monophasic Design

Monophasic ZVS Design

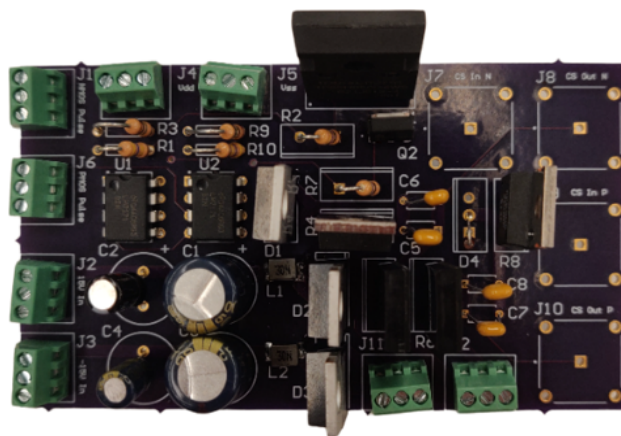

Biphasic Design

2.2 Requirements & Constraints

Requirements:

- As set by the client:
 - Design and Create a Device that does the following:
 - Generates Magnetic Fields of 500 Gauss at minimum
 - Pulses with rise time of less than 100 ns
 - Programmable Control of the magnetic field generation
 - Uses a source voltage of, at most, 15 V (DC)
 - Size of the circuit board is no greater than 3.5" by 2"
- As set by the team:
 - Improve upon the design by the 2019-2020 Design Project Team
 - Design a PCB with no daughter board
 - Decrease the overall rise time to 100 ns
 - Reduce the noise in the resultant signal so the signal is stable for most of the pulse
 - Simulate if rise time and signal stability can be improved by the use of a GaN MOSFET transistor or other components/methods
 - Implement Team Specific Goals
 - Identify a range of frequencies for the device to operate at, and optimize the circuit design to operate at said frequency range
 - Implement the previous teams circuit design in ADS and Multisim for future
 - Implement and compare the two major design ideas: Monophasic & Biphasic

Constraints:

- The source voltage of the circuit cannot be over 15 V (DC)
- Component purchasing must stay within the budget of \$500

2.3 Engineering Standards

1. IEEE 370-2020 - IEEE Standard for Electrical Characterization of Printed Circuit Board and Related Interconnects at Frequencies up to 50 GHz

An important part of the project is to take a tested circuit on a breadboard and to print it onto a PCB for future testing. The standard here will establish guidelines for the group when it comes to design a PCB later on during this semester.

2. IEEE C95.1-2019 - IEEE Standard for Safety Levels with Respect to Human Exposure to Electric, Magnetic, and Electromagnetic Fields, 0 Hz to 300 GHz

Safety is an important aspect of this project that needs to be taken into consideration. Although the electromagnetic pulse generator is not very strong, it is crucial to understand what electromagnetic fields can do to humans when exposed to it during the group's testing phase of this project.

2.4 Intended Users and Applications

The use of this product will be an addition to existing products. The intended immediate users will be companies that create medical or routing equipment and need this product to add to their product. Secondary consumers will be those that use the equipment that our product has been added to.

This device will be used in networking systems to increase the bandwidth of the system via magneto-optic switching. This concept uses the Faraday effect, which is a change in the polarization of the traveling EM wave through the optic cable caused by an outside EM field. Since this switching is faster than current systems used, we can achieve a larger bandwidth in our network. The larger bandwidth will be able to host more users, thus being more cost effective in theory.

3 Design

3.1 Summary

Given the work done by previous groups who worked on this project, the general design of the circuit was readily available for our use. To improve the design, there were a number of components and design additions that were debated and implemented. For the components, the areas of focus are the magnetic field coil which generates the magnetic field, the capacitor bank which drives the pulse, the MOSFET used for switching, and the flyback filter. For design additions, implementation of a Monophasic or Biphasic circuit was discussed, and Zero Voltage Switching implementation was also discussed.

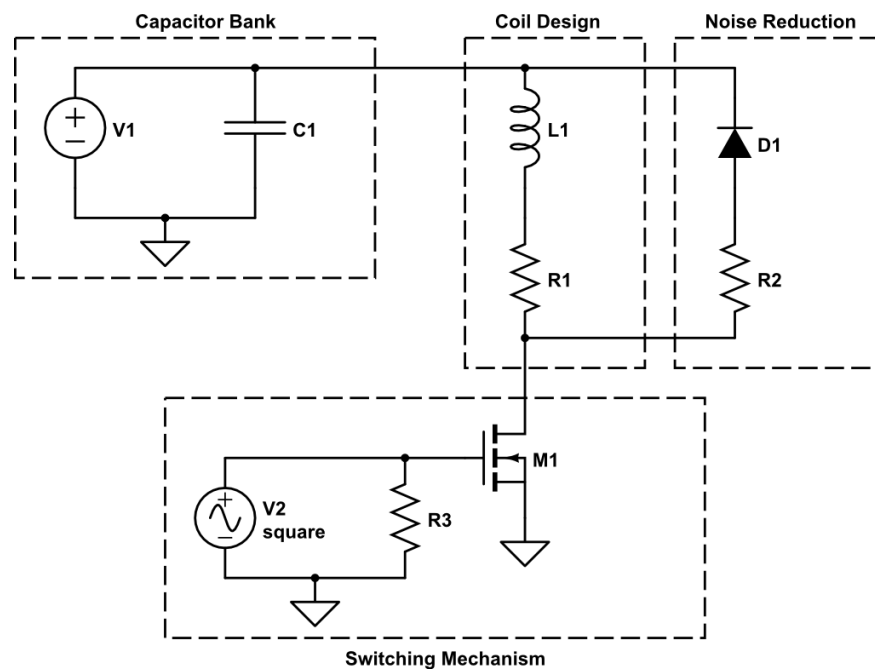

As shown above, we divided our circuit into four main sections that are crucial and the basis to a magnetic field generator.

- The Capacitor Bank: Provides the circuit with the desired surge of current to supply the coil to reach 500 Gauss.
- The Coil Design: Contains the coil designed by the team members which takes in a certain amount of current to reach 500 gauss. The current sense resistor R_1 is used to measure the current in the coil.
- The Noise Reduction: Contains a diode and a resistor in series to reduce the oscillation of the circuit after the MOSFET closes.

- The Switching Mechanism: Includes the pulse wave generator connected to the gate of the MOSFET turning it on and off letting current flow through the coil and then stopping the current.

3.2 Design Considerations

3.2.1 Coil Characteristics

The magnetic coil of the circuit is the component responsible for generating the pulsed magnetic field. To accurately simulate and design this coil, the magnetic field and inductance were approximated using equations¹ (1) and (2), respectively. These equations are used for a single coil, specifically. For later versions of the circuit that include a Biphasic Design, dual-coil designs were examined, such as layered coils and a Helmholtz coil², to implement with the two separate switching sides.

$$B = \frac{\mu NI}{\sqrt{l^2 + 4R^2}} \quad (1), \quad L = \frac{\mu N^2 \pi R^2}{\sqrt{l^2 + 4R^2}} \quad (2)$$

The table below shows the final coil characteristics we used in our PCB design. We've split them up into monophasic and biphasic coils. The basic design principle we had to get an efficient coil is to minimize the length of the coil, so our length in the end would be close to the diameter of the wire multiplied by the number of turns.

In the biphasic design, we are using an intertwined coil which means our length will double. In our final coil for biphasic however, we halved the number of turns so we could keep the same length. The difference is that doubling the length will give us less current needed to reach 500 gauss and halving the turns will give us less inductance.

Coil	Turns (N)	Length, l (mm)	Radius, R (mm)	Inductance, L (nH)	Current Needed, I (A)
Monophasic	10	3.0	37.5	17.9	12.32
Biphasic	5	3.0	37.5	4.72	24.65

3.2.2 Capacitor Bank

As shown in equation (1), to generate a large magnetic field using the coil, a large current is necessary. Additionally, a current that is too large would risk damaging sensitive components, such as the current sense resistor and the switching MOSFET. Using the definition of Current

¹ Pritchard, John W., Mani Mina, and Robert J. Weber. "Magnetic field generator design for magneto-optic switching applications." *IEEE transactions on magnetics* 49, no. 7 (2013): 4242-4244.

² Ibid.

(3), the current can be increased by a larger change in charge over a shorter period of time. A capacitor bank achieves this by storing charge across the bank while the MOSFET is switched off. When the switch is turned on, the stored charge will ‘rush’ across the coil over the short period of time the switch is open, generating a large current.

$$I = \frac{\Delta Q}{\Delta t} \quad (3)$$

3.2.3 MOSFET Considerations

Given that the speed at which the circuit will operate determines how successful the design works, and that said speed is considerably high, it was important that an ideal MOSFET was chosen. While Silicon-based MOSFETs are optimized for high frequency usage, the previous senior design group has experimented with implementing GaN transistors in their design. Research has shown that GaN transistors are capable of performing at high frequency, showing lower rise time and faster fall time.³ Since a faster switching speed is desired, a GaN transistor was chosen. Listed below are the factors we looked into and its tradeoffs.

- We are choosing n-channel MOSFETs for monophasic designs because they have faster switching capabilities than p-channel. The tradeoff is that PMOS is cheaper since it’s easier to manufacture and has higher yield.
- We’ve found that using higher VDC means faster rise time for our magnetic pulse, but we are limited to 15V by the client requirements, so using a MOSFET rated above 15 V is needed.
- The amount of pulsed current our MOSFET needs to handle will be based on the coil we use and we’ll need to calculate that later on when we build our coil, but we can assume it has to be higher than 30A based on previous groups designs. Higher current means the transistors are more expensive and physically larger.
- We are testing with GaN MOSFETs since they are a lot faster than silicon, but costs a lot more.

The final MOSFETs we’re using in our circuit is shown in the table below. The first one is the NMOS we’re using for our monophasic designs and the second is the PMOS we added in the biphasic design.

Name	V _{dss} (V)	I _{DM} (A)	P _D (W)	t _r (ns)	t _f (ns)	R _{DS(on)} (mΩ)	C _{OSS} (pF)
TP65H035G4WS	650	240	156	10	10	41	147
TSM480P06	-60	-64	40	42.4	16.4	65	85

³ Theh, Wei S., N. Prabhu Gaunkar, and Mani Mina. "GaN-based fast, high output magnetic field pulser." *AIP Advances* 11, no. 2 (2021): 025118.

3.2.4 Filter Design

With the switching speed being extremely high, it is reasonable to assume that not all of the charge stored in the capacitor bank will be emitted through the MOSFET in a single switching cycle. Because of this, a flyback diode is connected to the source of the MOSFET to dissipate this excess in charge. Otherwise, should the charge remain, it will cause the waveform at the coil to become unstable, increasing the signal's magnitude the longer the device is used.

3.2.5 Monophasic or Biphasic

When a magnetic field is pulsed from the coil, there is residual magnetic field after the demagnetization process which was shown by Prichard et al¹. This residual current will cause a slower fall time. This is where the idea of a biphasic current comes into play. By using two coils, we can use the second coil to remove the residual magnetic field of the first coil and hopefully decrease fall times. In the circuit done by Prichard et al.¹ they found that they can decrease the fall times by 130ns but⁴ suffered a 10% amplitude loss.

There is also another typology that can remove residual magnetic fields from the coil. This design takes inspiration from an inverter design in order to pull circuit up to the positive voltage supply and down to the negative voltage supply. This means the design can be kept as a monophasic design with a single coil. When the NMOS is open and PMOS is closed, the inductor is connected to positive DC and a surge of positive charges from capacitor C1 for the magnetization. Then when the NMOS is closed and the PMOS is open, the inductor is pulled down to the negative DC voltage supply and it rapidly charges the capacitor with negative charge from C2. This helps demagnetize the coil and remove any residual magnetic field created from the magnetization⁴.

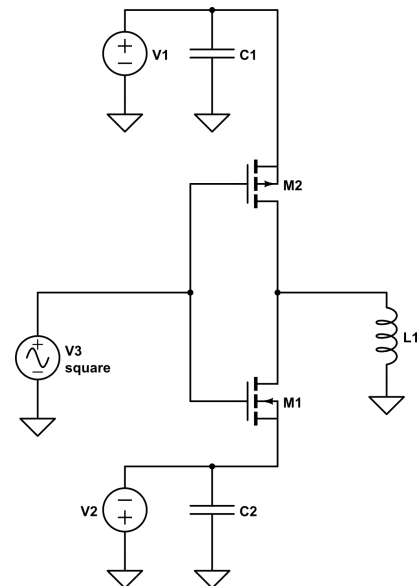

3.2.6 Zero Voltage Switching

While switching the MOSFET, without implementing zero voltage switching (ZVS) into our design, we will encounter power losses during the turn on and turn off of the MOSFET. This happens because prior to the turn on of the MOSFET, the V_{DS} is high which causes it to crossover with the I_D creating power loss. V_{DS} is also the charge of the MOSFET's C_{OSS} , so if we were able to “trick” the capacitor into discharging early, we can achieve ZVS. In short, the current I_D rises when the V_{DS} is at zero. We can also achieve ZVS by delaying the rise of I_D so that the V_{DS} can reach or be near zero.

⁴ Selvaraj, J., and Mani Mina. "Enhancement for high-speed switching of magneto-optic fiber-based routing using single magnetizing coil." IEEE Transactions on Magnetics 53, no. 11 (2017): 1-4.

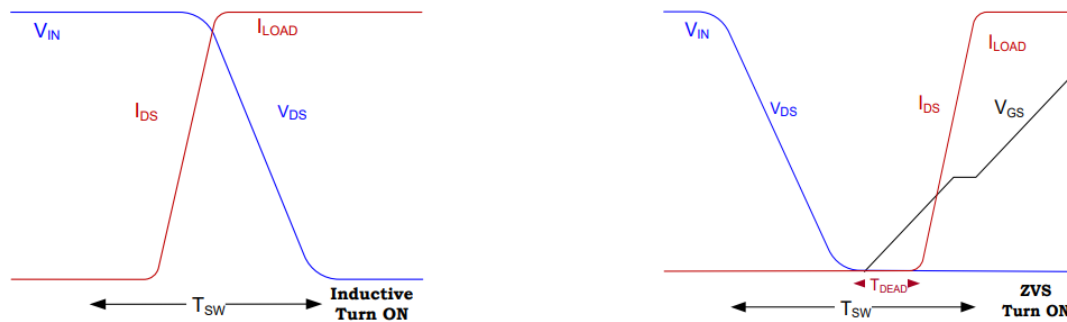

3.3 Prior Work

Schematic of the circuits from the prior senior design groups were provided. Also, research papers and documents relating to the design topic: a high-speed magnetic field generator was supplied by our adviser. We tried to modify the (Sdmay20-39) design circuit by changing the capacitor and inductor values to analyze the result using Multisim simulation, specifically how these changes affect the current across the inductor, which is the magnetic field. Every member of the team modified the circuit's components and wrote a report about the findings. This was helpful to understand how the circuit functions and the key to knowing what to modify to enhance the previous group design. The previous group met some of the requirements but with an unstable result. They generated a magnetic field of 500 gauss, Pulses with a rise time of 47 ns, and used a source voltage of 25 V (DC). What should be done: Generates Magnetic Fields of 500 Gauss at minimum, Pulses with rise time of less than 100 ns, Programmable Control of the magnetic field generation, Uses a source voltage of, at most, 15 V (DC), and Size of the circuit board is no greater than 3.5" by 2."

3.4 Basic Design

A basic design was created using the aforementioned design considerations. Iterating from previous senior design groups, the basic design consists of the following elements, all shown in the Figure below:

- DC Input Voltage Source (V1)
- Capacitor Bank (C1)
- Magnetic Coil (L1)
- Flyback Filter (D1 and R2)
- GaN MOSFET Switch (M1)
- Function Generator (V2)
- Current Sensing Resistor (R1)

From this design, further additions can be made such as a Zero-Voltage Switching and a Biphasic Circuit Design.

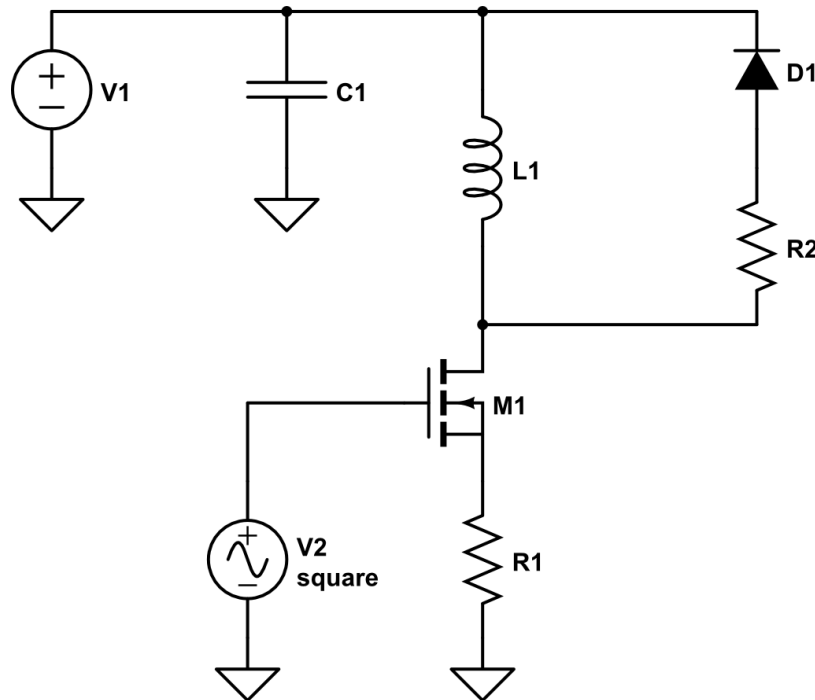

3.5 Zero Voltage Switching Design

We designed a circuit for zero voltage switching because of the benefits described. In short, we can minimize the power dissipation during the turning on and off of the MOSFET by bringing the V_{DS} close to 0 and delaying the rise of the I_D . We can see that our design below follows the basic design principles from previous circuits. We have four basic design elements in our circuit design; the capacitor bank, coil for generating magnetic field, filter, and a switching mechanism.

The L2 inductor produces the 500 gauss of current we need. Diode D1 helps to prevent current from going into our power supply when the MOSFET turns off. R1 is the current sense resistor used to measure the voltage and allow us to calculate the current going through the coil. The two filters in our circuit help us reduce the oscillation in the pulse.

The zero voltage switching elements of this circuit is L1 and the filter made by C2, R2, and D2. The L1 in the circuit helps slow the rise of I_D to allow the V_{DS} to fall and minimize the switching losses. D2 in the circuit acts as a secondary voltage source that the C_{OSS} in the MOSFET can clamp on to so that we can get V_{DS} to go near 0. In this case, the V_{DS} will go to 0.7V when the MOSFET turns on because of the diode producing 0.7V when it's biased.

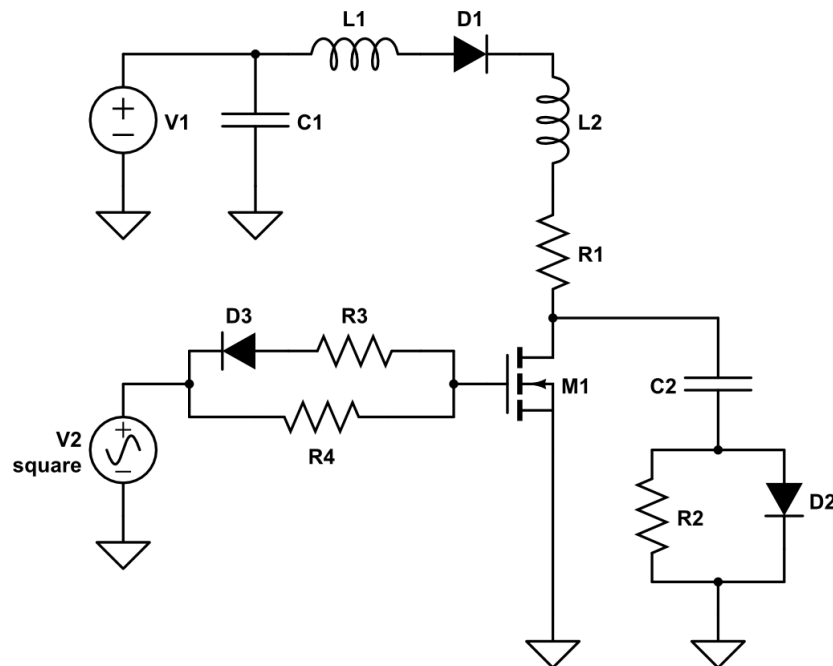

3.6 Biphasic Design

In previous literature, it has been shown that the number of magnetic field moments created by the magnetic coil can be increased by changing the orientation of the magnetic field.⁵ To induce this change, a second identical magnetic pulser is added to the original monophasic design, conjoined at the inductive load. This second pulser reverses the current direction using a combination of negative voltage sources, reversed components, and a P-type switching MOSFET, shown in the figure below. The inductive coil design for this circuit can use the aforementioned coil designs; Helmholtz coil, intertwined coils, or two separate coils. The resulting waveform is expected to be reflective across the time-axis. However, the same literature showed that the Biphasic design has limitations when compared to the monophasic design. In general, the frequency at which there exists no interference in the output signals is lower than the frequency at which a monophasic design can operate. The current that can be attained is noticeably lower (20A as opposed to 50A), which results in a lower magnetic field strength.

⁵ Prabhu-Gaunkar, Neelam, Nariminda Robert Bouda, Wei Shen Theh, and Mani Mina. "Design considerations for biphasic pulsed field generators used in portable magnetic sensor systems." In *2021 IEEE International Magnetic Conference (INTERMAG)*, pp. 1-4. IEEE, 2021.

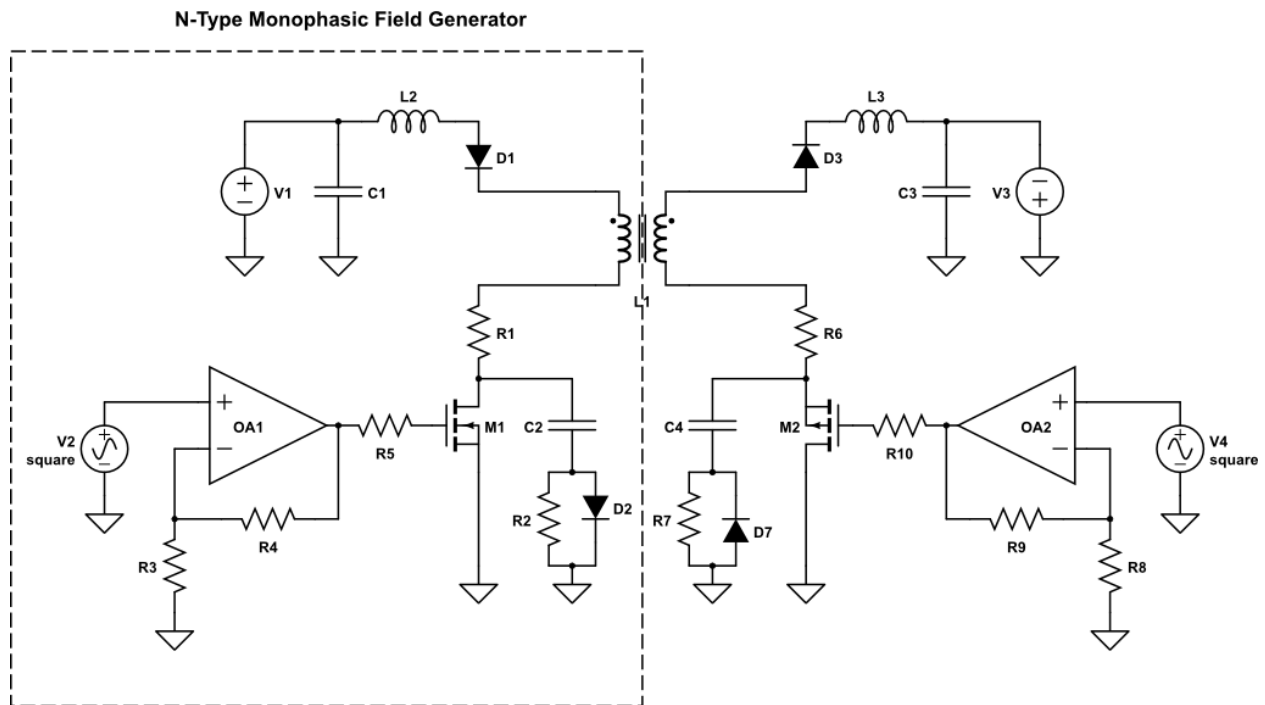

3.7 PCB Design

PCBs were designed for the basic design, the monophasic ZVS design, and the biphasic design with ZVS. The PCBs mainly use through hole components to allow an easier transition from breadboard to PCB. The circuits use terminal blocks to connect the inputs to the circuit as well as a terminal block for the coil so different coil designs can easily be switched out. Each circuit except the biphasic design has BNC ports for measuring the output on the oscilloscope. The biphasic design does not have BNC ports because not enough female BNC ports were ordered. The waveforms from the biphasic design could still be recorded through the utilization of oscilloscope probes. All boards were made to be 3.5" x 2", meeting the size requirement.

3.7.1 Basic Design PCB

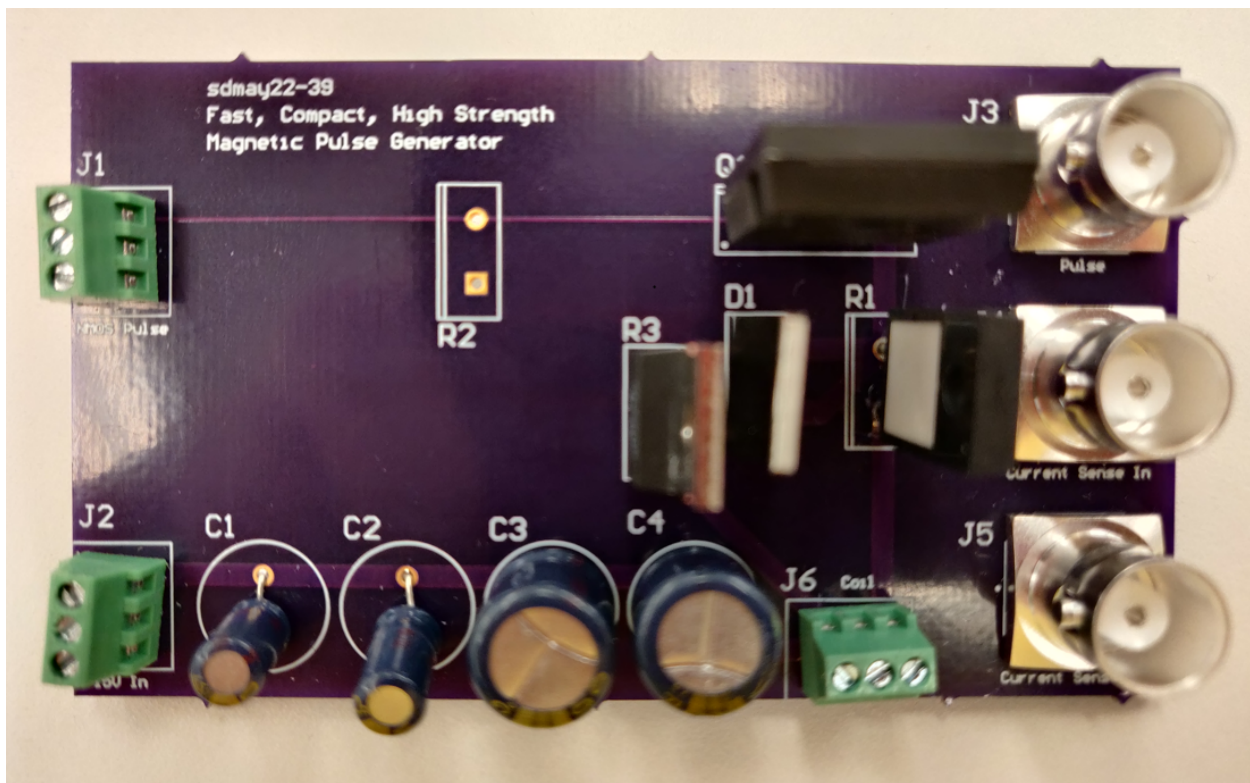
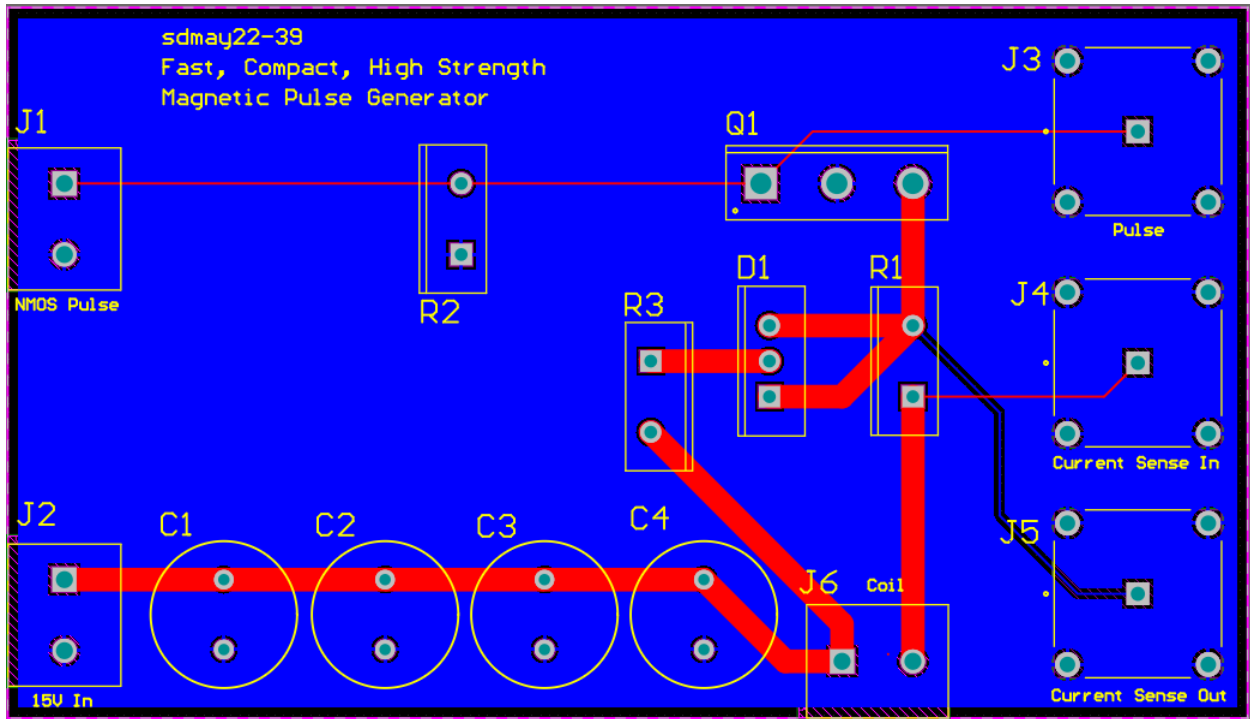

3.7.2 Monophasic Zero Voltage Switching PCB

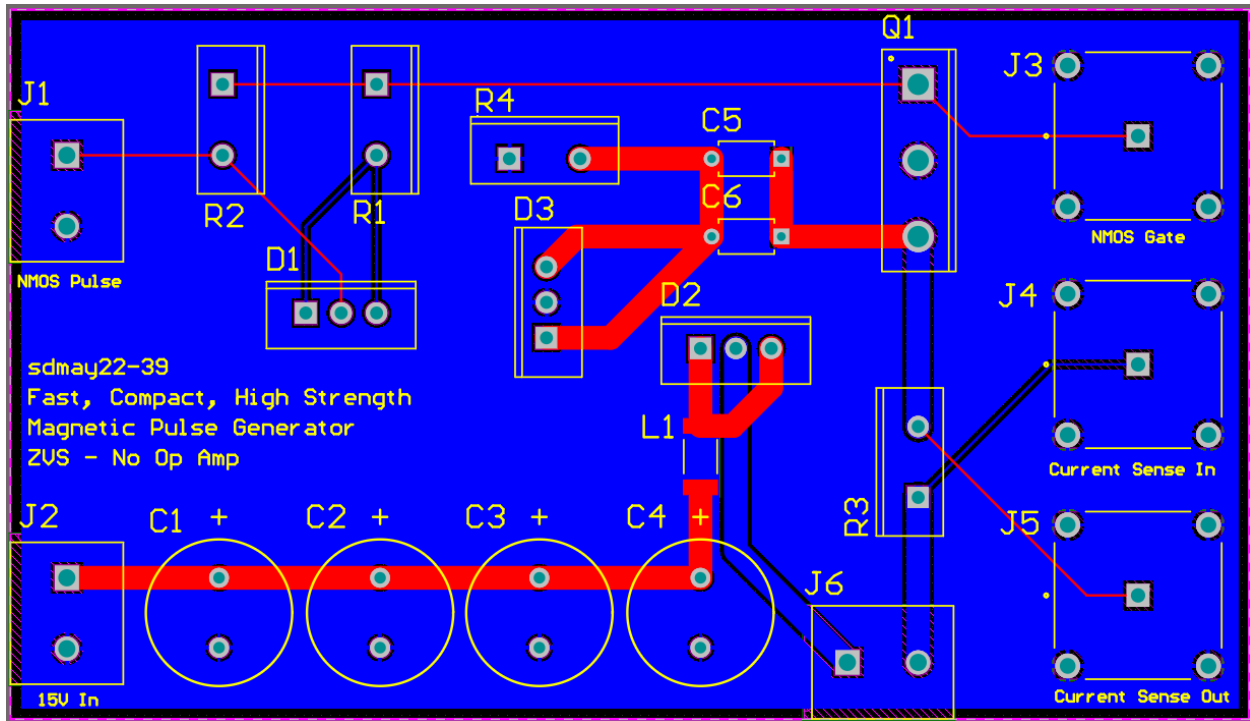

3.7.3 Biphasic with Zero Voltage Switching PCB

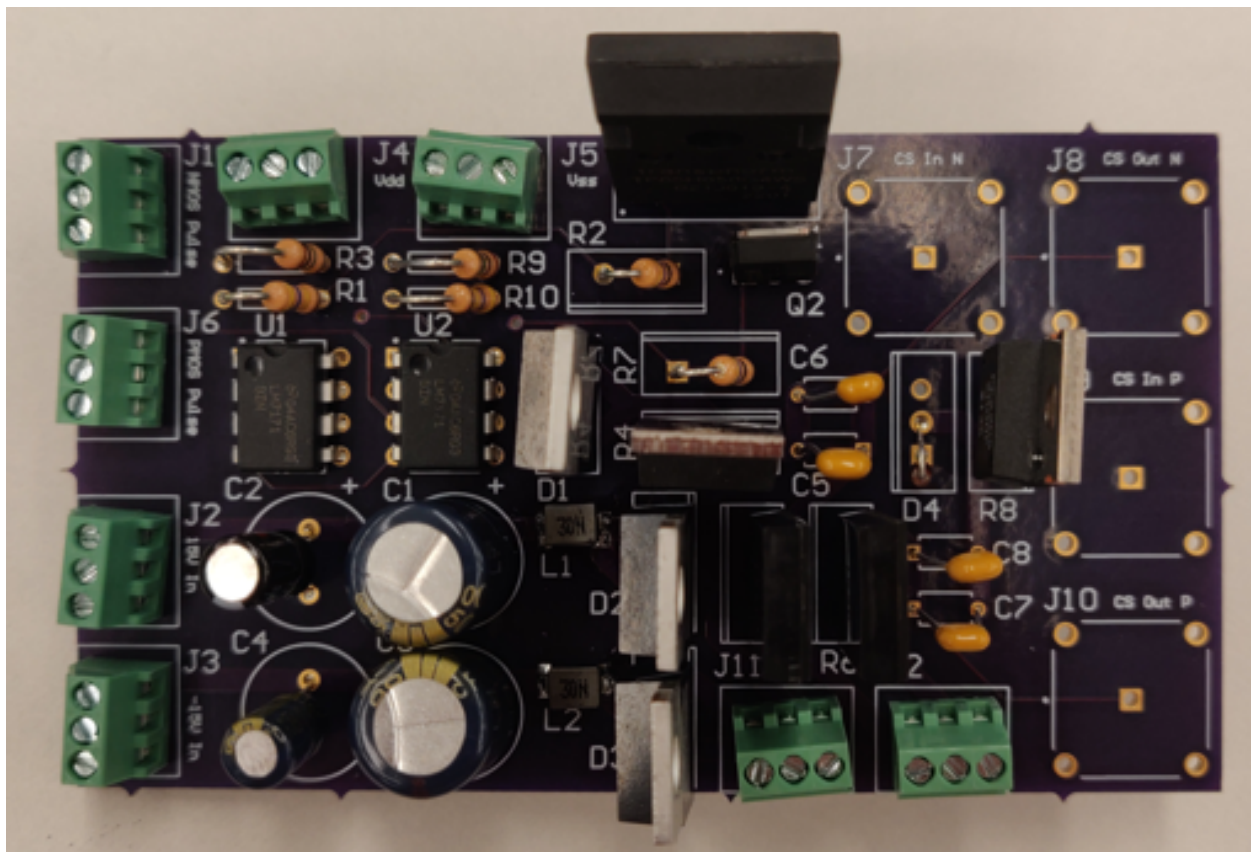
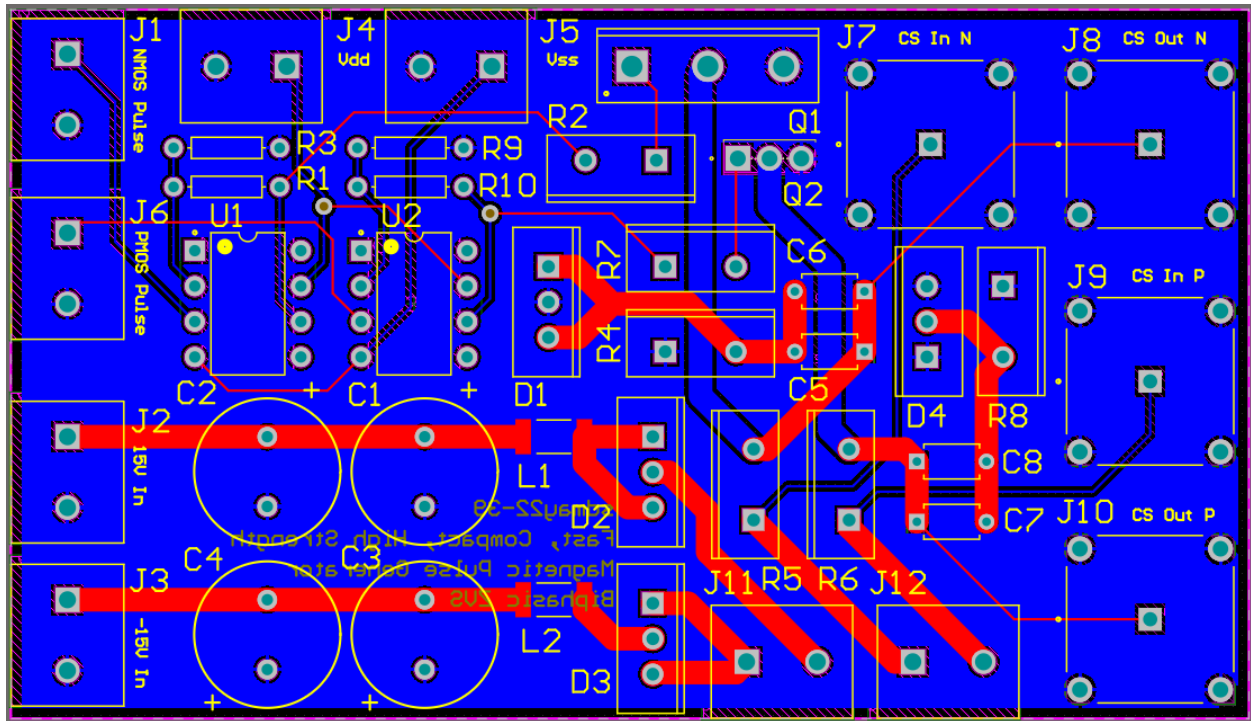

4 Testing

4.1 Introduction

The team will be testing the strength of the magnetic field made by the inductive coil. This unit is measured in Gauss. There are many methods to test the magnetic field strength of the circuit. Ideally, the team wants to utilize a Gauss meter to find the magnetic field strength, however, the team will instead be using an oscilloscope to measure the voltage over the current sense resistor and the rise time of the pulses because a Gauss meter was unavailable to use. From there, the team will use Ohm's law to find the current running through the current sense resistor which in result can let us know the current in the inductive coil we made. With equation (1), the magnetic field strength can be calculated.

4.2 Testing Results

Below are the results from testing the various PCB designs. The setup for these tests can be found in [Appendix I](#).

4.2.1 Basic Design

For the basic design, we found that our test was successful at a frequency of 1MHz, and we also tested the circuit at frequencies 500kHz, 2MHz, and 3MHz. The image below shows the math function of the difference in voltage before and after the current sense resistor. Using the cursors, we found that the rise time was around 27ns, meeting the required 100ns or less. The current sense resistor was a 0.05Ω resistor, so we needed the voltage across the resistor to be about 616mV or greater to meet the 500 Gauss requirement, and the waveform shows that it meets that requirement. Through the change of values in the pulse generator and DC power supply, the magnetic field generation becomes fully controllable by the user as well.

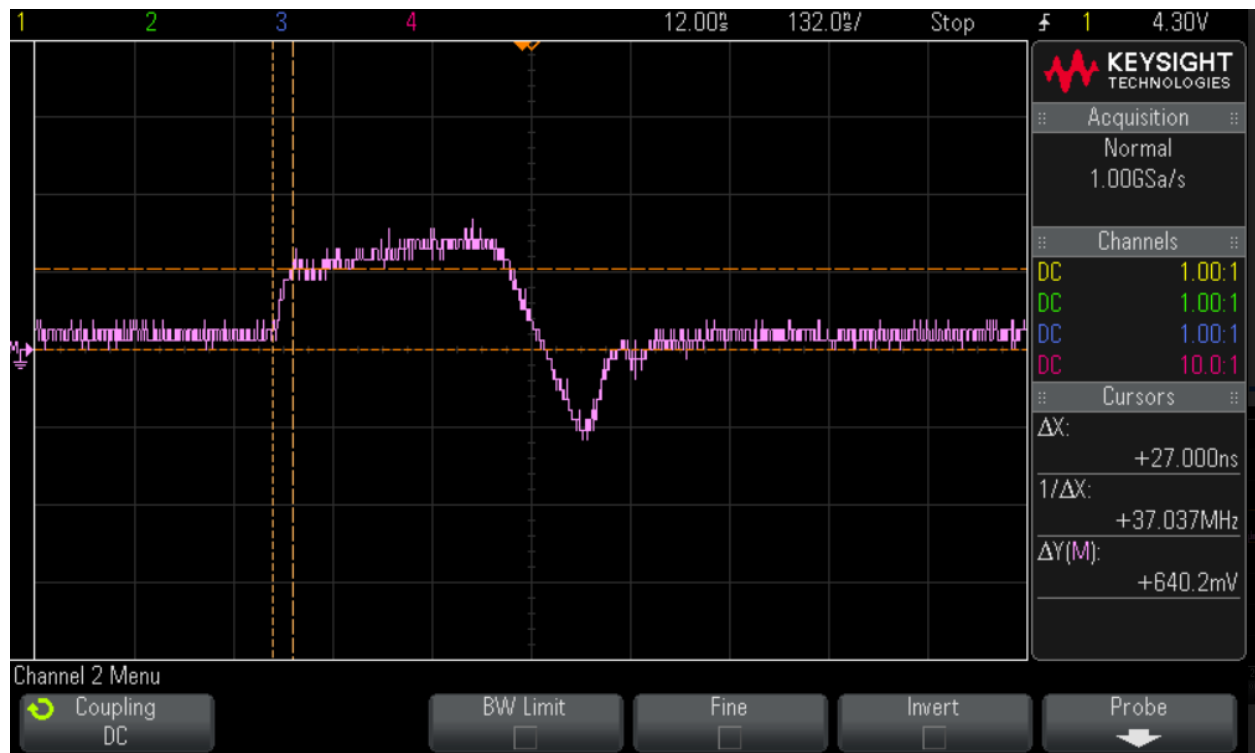

Pulse Generator Settings

Frequency: 1 MHz

Pulse Generator Amplitude: 6 Vpp

Pulse Generator Offset: 6 V

Duty Cycle: 20%

Results

Rise Time: 27 ns

Amplitude: 640 mV

Current: 12.8 A

Next, we took the CSV of the waveform and plotted it in MATLAB. Below is a plot of the waveform on MATLAB. In MATLAB, it was easier to find the rise time since we could find the point that is about 10% of 640mV and the point that is about 90% of 640mV, then find the difference in time between the 90% and 10%. The plot shows that our basic design meets the requirements since the pulse is over 616mV, therefore over 500 Gauss, and the rise time is about 22ns.

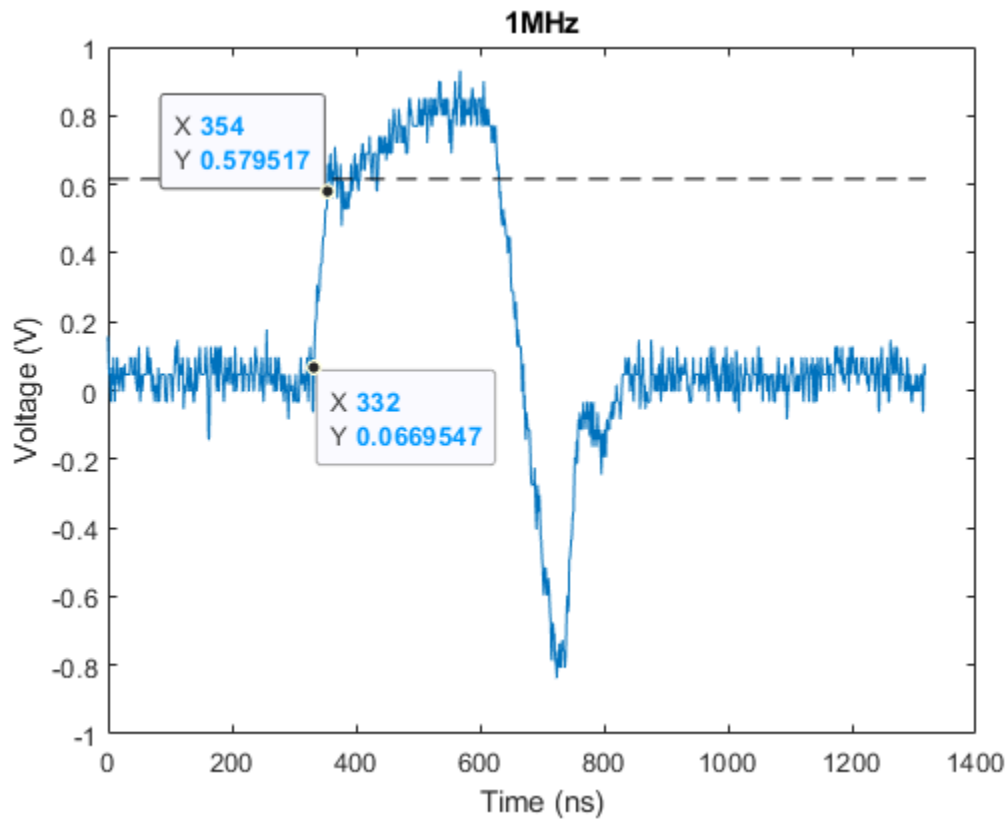

After finding that the circuit meets the requirements at 1MHz, we tried other frequencies. Below is the waveform at 500kHz (the other pulse generator parameters remaining the same). This pulse is also above 616mV and the rise time is about 20ns, meeting the requirements.

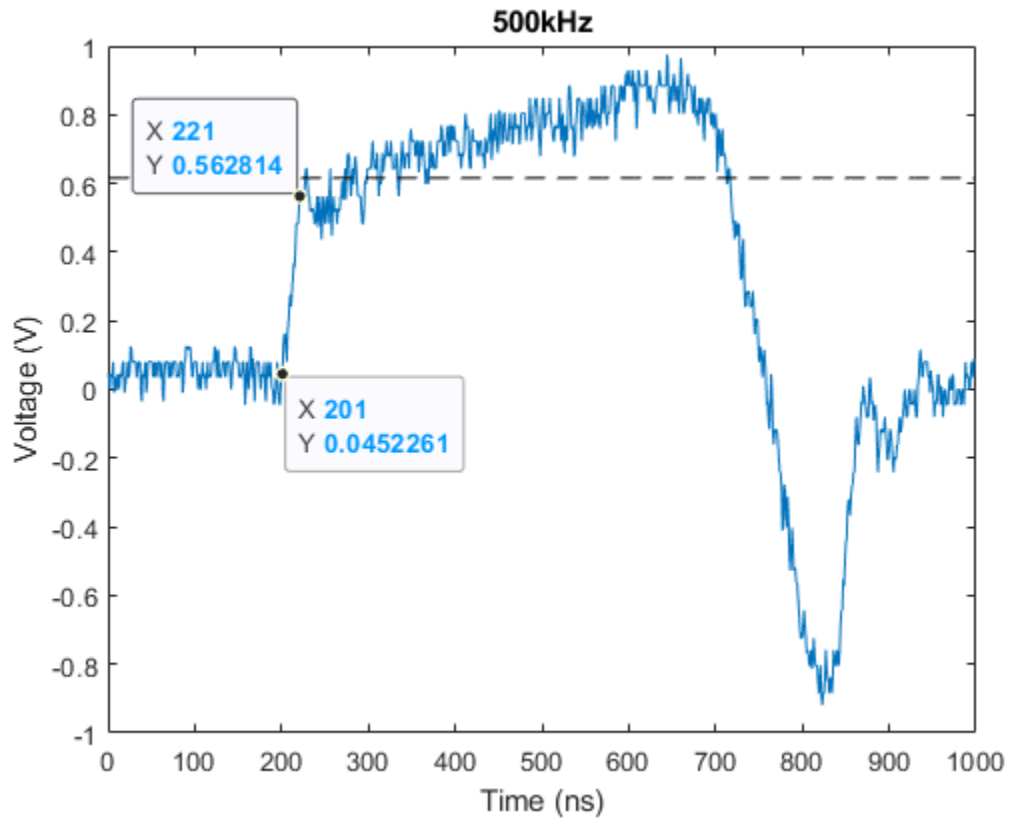

Next was 2MHz, shown below, and this had some trouble staying above 616mV and had a rise time of around 19ns.

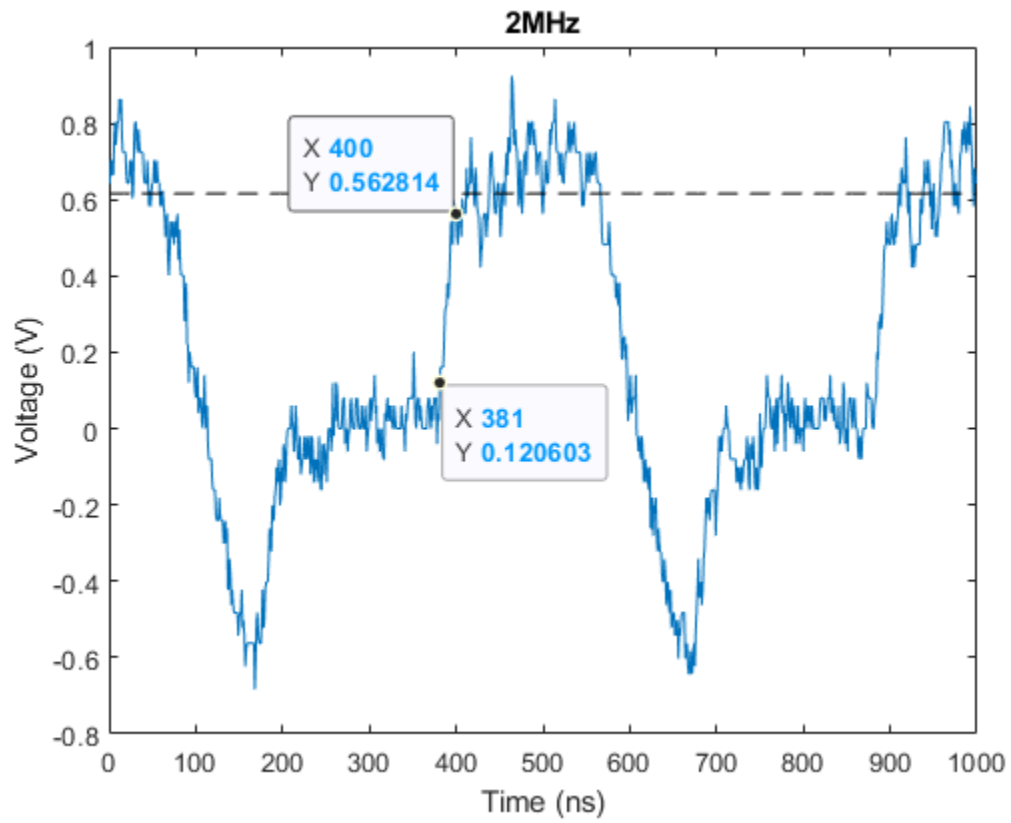

The last frequency we tried was 3MHz, shown below, and while it did have a rise time of around 17ns, it was just short of 616mV, so 3MHz is the limit for this circuit.

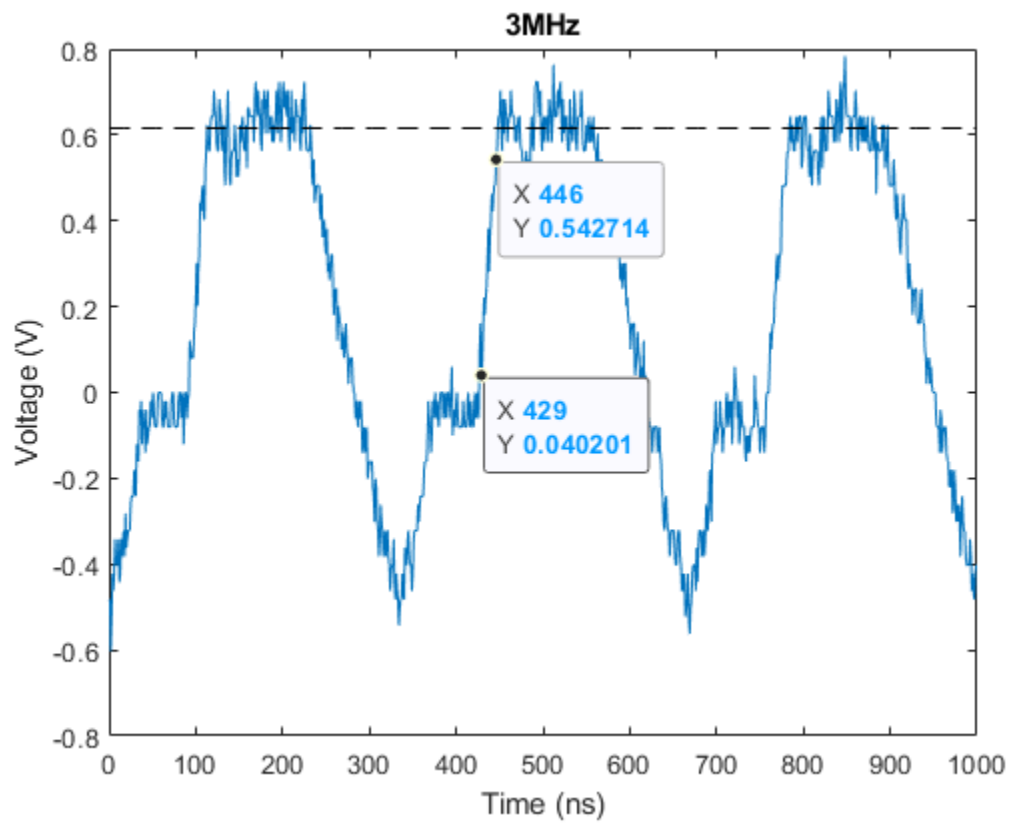

4.2.2 Monophasic ZVS Design

For the monophasic ZVS design, we needed to find the power dissipation during the rise time along with the rise time and voltage across the current sense resistor. From testing, we set the waveform generator to the same settings as from the basic design test where the frequency was 1MHz, amplitude was 6Vpp, offset was 6V, and duty cycle was 20%. We found that at a frequency of 1MHz, the voltage oscillated above and below 616mV during the pulse, so we decreased the frequency to 500kHz. The pulse was also having trouble staying above 616mV at a duty cycle of 20%, but a duty cycle of 15% resulted in a waveform that reached and stayed above 616mV during each pulse. The graph below shows the resulting waveform after reducing the frequency to 500kHz and duty cycle to 15%, and we found that our rise time was 47ns, meeting the requirement.

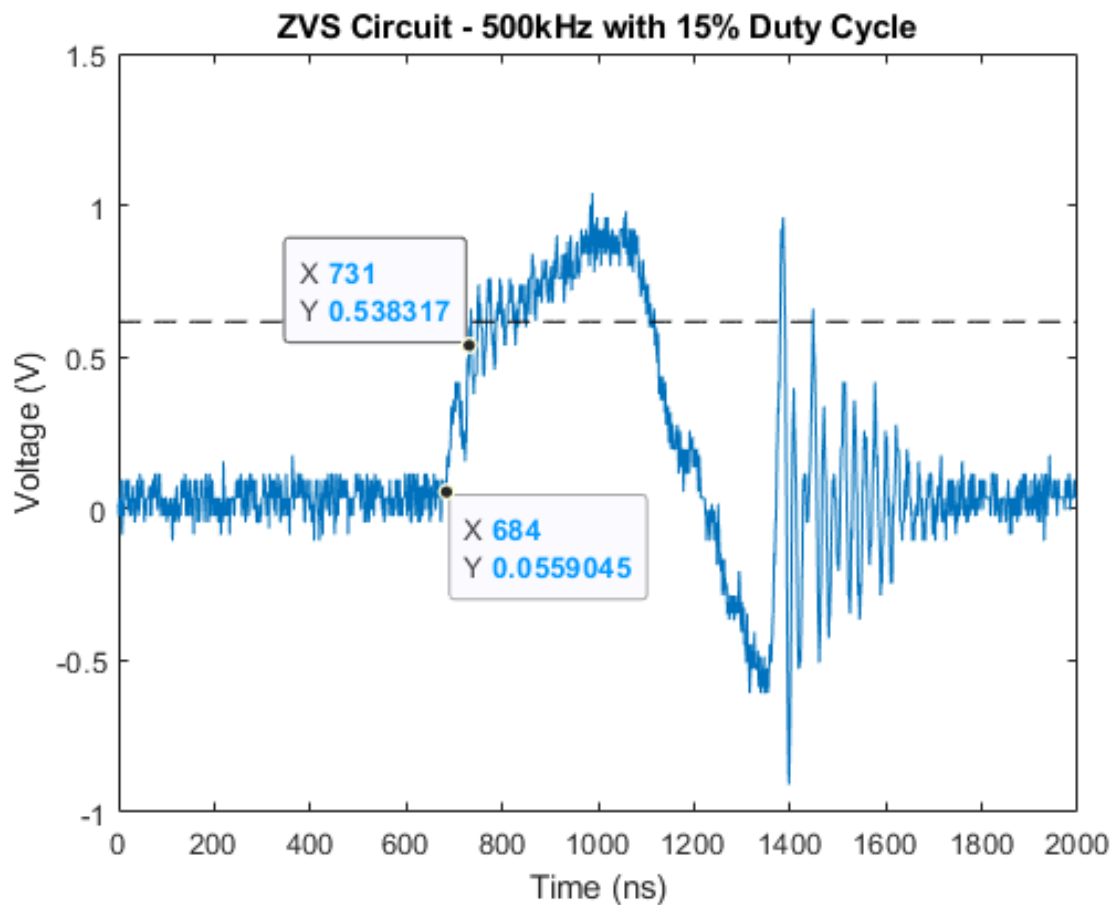

While the rise time was greater than the basic design, the main goal of this circuit was to reduce the MOSFET drain to source power dissipation during the rise time. The power dissipation could be found by multiplying the current across the current sense resistor by the drain to source voltage. The graph below shows the power dissipated across the MOSFET, and we found that the maximum dissipation during the rise time was about 70W.

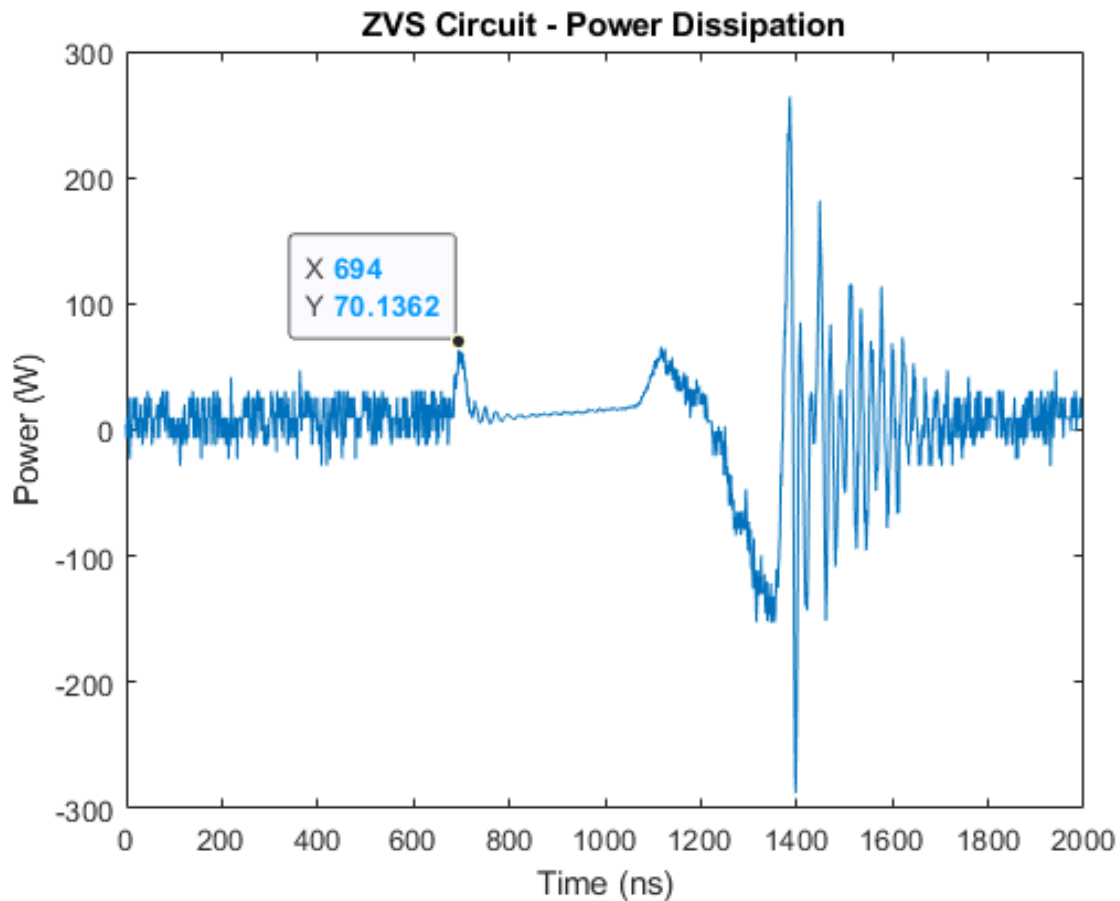

Next was to compare with the basic circuit. We graphed the power dissipation of the basic circuit, shown below. We found that the power dissipation during the rise time in the basic circuit was less than the ZVS circuit, which is opposite to what we were expecting. While the ZVS circuit did meet the rise time and magnetic field strength requirements, it did not meet our expectations of reduced power dissipation.

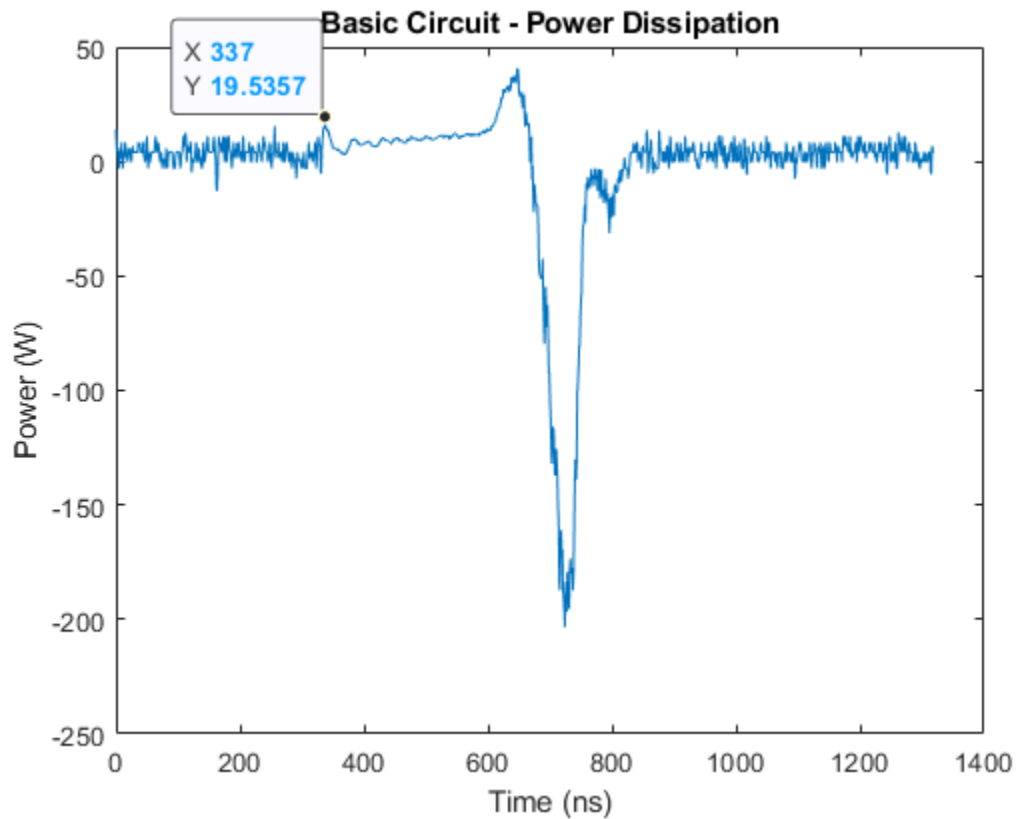

4.2.3 Biphasic Design

For the biphasic circuit, we followed the setup in Appendix I, but found that the NMOS side was not giving the output we expected. For the output, we expected the current to alternate between flowing through the NMOS side of the circuit and flowing through the PMOS side of the circuit, but the graph below shows that the voltage across the NMOS side current sense resistor, in blue, does not pulse (PMOS side in red). We attempted to adjust the settings of the waveform generator, but we were not able to get the NMOS side to pulse.

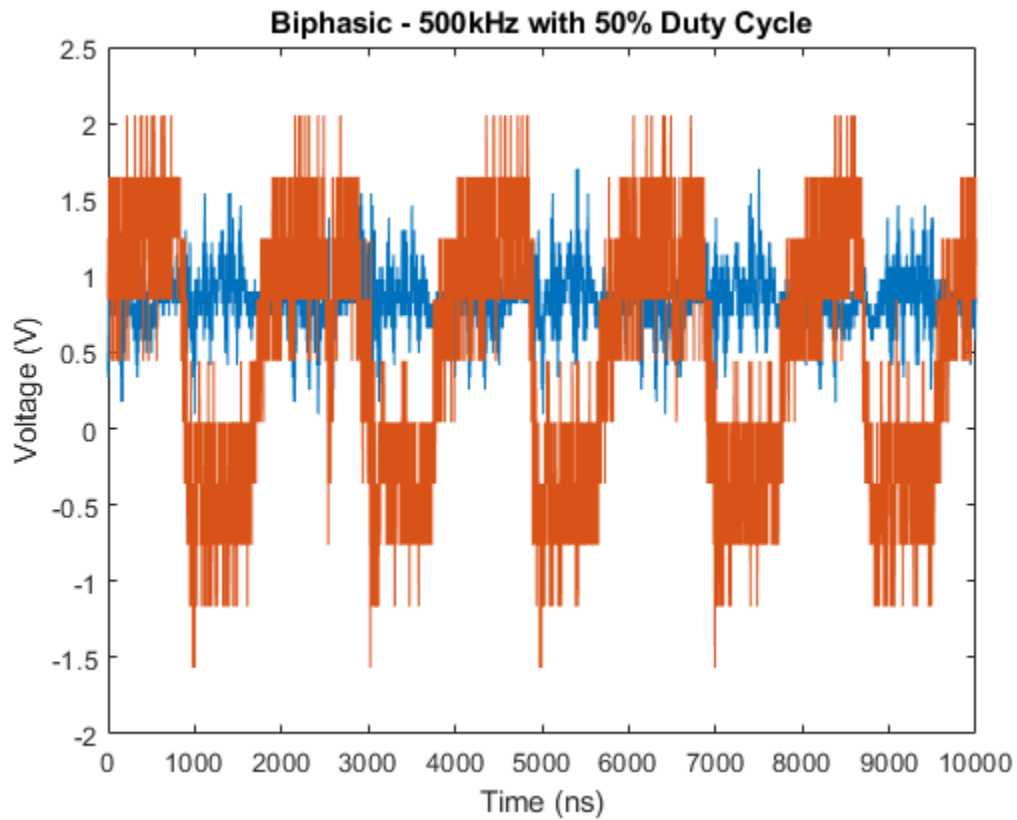

4.3 Common Issues

4.3.1 Breadboard

Since we are working with such high current in order to produce the required magnetic fields we need, our components usually run very hot. We've had very little components burn out on us because we specifically ordered high wattage parts. The parts were generally rated for 50W. These components can usually withstand up to 300°F, but our breadboard cannot. Because of this there will sometimes be holes burnt in our breadboard and the plastic around the holes would melt. Typically this will just cause a bad smell, but sometimes sections of our breadboard would stop working because the melted, enlarged holes in the breadboard unseated components. To prevent this, we only ran the circuit for a few seconds to get the waveform and we can pause the oscilloscope to put our cursors into place and get the measurements. Another issue with the breadboard is the wires and components add inductance to the circuit. That inductance ultimately slows the rise time of the magnetic pulse. Along with the wires and components, any exposed wire that was bent had the possibility of interfering with the magnetic pulse waveform because a bent wire essentially creates an antenna that propagates a weak magnetic field.

4.3.2 Power Supply

Working with high current through our circuit also generates a lot of issues from our power supply. Specifically, our power supply always gets overloaded and its current maxes out causing the voltage to limit itself. Discussing this with our advisors, a few ideas stood out; our circuit was getting shorted and we weren't dissipating the power properly in the coil creating a "cascading effect".

In order to test if the circuit was getting shorted, we built the design back up from scratch adding components one by one to identify the issue. Even at its most basic form, the voltage was still getting limited, so we concluded that our circuit wasn't shorting since the design was used in a lot of the research papers. Another idea is that our current wasn't dissipating properly in the coil causing the circuit to keep pulling more and more current from the power supply. We tested this idea and by adding a flyback diode, we saw that our circuit was using less current, but it only reduced the current draw from the power supply by around 10%. Experimenting with different diode types (General purpose, Zener, Schottky) and their various parameters is something that can be done to reduce the current draw from the power supply.

Towards the end we feel as though the voltage limitation is a characteristic of this circuit after doing rigorous testing to identify the issue. This is something we just have to work around using a few different methods.

- Decreasing the duty cycle of the function generator will cause less current draw. A 20% duty cycle was usually the highest percentage the circuit could utilize. Any higher of a duty cycle and the pulser would have a magnetic field strength below 500 Gauss.

- Increasing frequency of the circuit will cause less current draw.
- Increasing the amplitude of the gate voltage to get more current will sometimes give less current in the coil because our power supply maxes and limits the current. This means we have to tweak the gate voltage so we're only getting what we need.
- Changing the coil characteristics so we need less current to achieve 500 Gauss. This will usually increase our rise times because of the higher inductance.

4.3.3 Oscilloscope Interference

When working with an oscilloscope, we encountered an issue worth mentioning here. Oscilloscopes can measure magnetic field interferences which can result in abnormal waveforms. Depending on the environment, magnetic pulses from devices around the magnetic field pulse could interfere with its waveforms. We mainly worked in our senior design lab, and some days when the lab is full of other groups, we can get unusual results. We usually have to test the circuit first to make sure there is no error in the wirings, but if we cannot identify the issue, interference that our oscilloscope is picking up is a possible factor.

5 Closing Material

Conclusion

Looking back on this project, we learned a large amount about circuit designing and testing. We went through several design iterations before designing and ordering the three PCBs designs. Each setback taught us something new about the characteristics of the circuit we were designing. Along with lessons learned, we gained more experience with softwares such as Multisim, ADS, and MATLAB along with physical equipment such as power supplies, oscilloscopes, and soldering irons. The team initially set out to make a monophasic design that would have an improved rise time over the previous groups. By accomplishing that goal through simulations fairly early on in the timeline of the project, we decided to shift the goal post and try experimenting with new designs that could reduce power loss in the circuit. We invested a large amount of our time and resources into implementing a zero volt switching design that could reduce power loss in the circuit. We also looked into designing and testing a biphasic design. Our goal of the biphasic design is to expand the possible solutions in order to solve the problem our team was given. Although we were successful in creating two monophasic designs that could achieve the requirements given to us, the monophasic ZVS circuit did not achieve lower power loss across the MOSFET when compared to the basic monophasic circuit and the biphasic design needs more work to achieve the requirements given by the client. We hope that our team provided more information from the findings we got between all three of our designs so that future senior design groups and our client can further innovate on our design and ultimately solve the bandwidth bottleneck that presents itself with magneto optical switches in fiber optic networks.

Further Work

Although we have successfully made the monophasic designs meet requirements, there are improvements to make if we had more time. The first improvement would be to fix the power supply overload limitation with the circuit. Fixing this problem would increase the overall power running through the circuit which would in turn increase the magnetic field strength of the coil. Another problem we had was that there was a large amount of oscillation throughout the waveform of the monophasic ZVS circuit. Mitigating the oscillations would improve the stability of the monophasic ZVS circuit. Although we also intended on having the ZVS circuit reduce power loss, it actually increased power loss. Optimizing component values or redesign would be the next step in fixing the power loss in the circuit. The last improvement would be to make a more functional biphasic circuit. It did not fulfill any requirements. Due to time constraints, designing and testing was not fully implemented on this circuit. More design iterations needs to be done so that it could fulfill the given requirements.

References

- [1] Pritchard, John W., Mani Mina, and Robert J. Weber. "Improved switching for magneto-optic fiber-based technologies." *IEEE transactions on magnetics* 48, no. 11 (2012): 3772-3775.
- [2] Pritchard, John W., Mani Mina, and Robert J. Weber. "Magnetic field generator design for magneto-optic switching applications." *IEEE transactions on magnetics* 49, no. 7 (2013): 4242-4244.
- [3] Theh, Wei S., N. Prabhu Gaunkar, and Mani Mina. "GaN-based fast, high output magnetic field pulser." *AIP Advances* 11, no. 2 (2021): 025118.
- [4] Selvaraj, J., and Mani Mina. "Enhancement for high-speed switching of magneto-optic fiber-based routing using single magnetizing coil." *IEEE Transactions on Magnetics* 53, no. 11 (2017): 1-4.
- [5] Prabhu-Gaunkar, Neelam, Narimdinda Robert Bouda, Wei Shen Theh, and Mani Mina. "Design considerations for biphasic pulsed field generators used in portable magnetic sensor systems." In *2021 IEEE International Magnetic Conference (INTERMAG)*, pp. 1-4. IEEE, 2021.

Appendix

Appendix I: Operation Manual (Testing Procedure)

- Equipment
 1. Keysight EDU33212A Waveform Generator
 2. Agilent DSO-X 2024A Oscilloscope
 3. Keithley 2230G-30-1 Power Supply
- Breadboard prototype setup/procedure
 1. Attach dc power supply cables
 2. Power Supply Setup
 - Make sure output is turned off
 - Use 0-30V output
 3. Attach waveform generator inputs to the gate side of the mosfet
 4. Set waveform generator settings
 - Press setup button on channel 1 port
 - Press output load button on screen
 - Set to High Z
 - Press waveform button
 - Select square waveform
 - Frequency = 500kHz
 - Amplitude = 6Vpp
 - Offset = +3V
 - Phase = 0
 - Duty Cycle = 20%
 5. Attach oscilloscope probes to the current sense resistor
 - Probe 1 before current sense
 - Probe 2 after current sense
 - Attach probes to ground
 - Set to 10x
 6. Turn on the waveform generator output
 7. Turn on the dc power supply output
 8. Set oscilloscope settings
 - Auto-scale
 - Zero by pressing knobs on ports 1 & 2
 - Select math function: (source 1 - source 2)
 9. Press run/stop on the oscilloscope and turn off the dc power supply output

- Monophasic PCB prototype setup/procedure
 1. Solder Components onto the PCB board
 2. Insert the coil into the coil terminal
 3. Insert the DC power supply wire into the 15V In terminal block
 4. Power Supply Setup
 - Use 0-6V output
 - Set voltage to 6V and current limit to 2.5A
 5. Insert the waveform generator wires into the Pulse terminal block
 6. Set waveform generator settings
 - Press setup button on channel 1 port
 - Press output load button on screen
 - Set to High Z
 - Press waveform button
 - Select square waveform
 - Frequency
 - 1MHz for the basic circuit
 - 500kHz for the ZVS circuit
 - Amplitude = 6Vpp
 - Offset = +6V
 - Phase = 0
 - Duty Cycle
 - 20% for the basic circuit
 - 15% for the ZVS circuit
 7. Connect BNC cables from oscilloscope to PCB
 - Probe 1 after current sense resistor
 - Probe 2 before current sense resistor
 - Probe 3 to the MOSFET gate
 - Set channel ratios to 1:1
 8. Turn on the waveform generator output
 9. Turn on the dc power supply output
 10. Set oscilloscope settings
 - Auto-scale
 - Fit the whole waveform of channels 1 and 2 in the window
 - Select math function: (channel 2 - channel 1)
 11. Press run/stop on the oscilloscope and turn off the dc power supply output
 12. Use cursors to measure the rise time and amplitude of the math function

- Biphasic PCB prototype setup/procedure
 1. Solder Components onto the PCB board
 2. Insert the coil into the coil terminals
 3. Insert the positive DC power supply wire into the 15V In terminal block
 4. Insert the negative DC power supply wire into the -15V In terminal block
 5. Power Supply Setup
 - Use 0-6V output for the NMOS side
 - Set voltage to 6V and current limit to 2.5A
 - Use 0-6V output for the PMOS side
 - Set voltage to 6V and current limit to 2.5A
 - Flip the inputs so that the cable that goes to ground usually goes to the +6 port and the cable that goes to the +6 port usually goes to ground
 6. Insert the waveform generator wires into the Pulse terminal blocks
 7. Set positive waveform generator settings
 - Press setup button on channel 1 port
 - Press output load button on screen
 - Set to High Z
 - Press waveform button
 - Select square waveform
 - Frequency = 500 kHz
 - Amplitude = 4 Vpp
 - Offset = +2 V
 - Phase = 0
 - Duty Cycle = 50%
 8. Set negative waveform generator settings
 - Press setup button on channel 1 port
 - Press output load button on screen
 - Set to High Z
 - Press waveform button
 - Select square waveform
 - Frequency = 500 kHz
 - Amplitude = 1 Vpp
 - Offset = - 0.5 V
 - Phase = 0
 - Duty Cycle = 50%
 9. Connect BNC cables from oscilloscope to PCB
 - Probe 1 after current sense resistor of the NMOS side
 - Probe 2 before current sense resistor of the NMOS side
 - Probe 3 after current sense resistor of the PMOS side
 - Probe 4 before current sense resistor of the PMOS side

- Set channel ratios to 1:1
10. Turn on the waveform generator output
 11. Turn on the dc power supply output
 12. Set oscilloscope settings
 - Auto-scale
 - Fit the whole waveform of channels 1 and 2 in the window
 - Select math function: (channel 2 - channel 1)
 13. Press run/stop on the oscilloscope and turn off the dc power supply output
 14. Use cursors to measure the rise time and amplitude of the math function

Appendix II: Bill of Materials

Index	Quantity	Vendor	Part Number	Manufacturer Part Number	Item Description	Unit Price (\$)	Total Cost (\$)
1	4	Digi -Key	1707-TP65H03 5G4WS-ND	TP65H035G4WS	GANFET N-CH 650V 46.5A TO247-3	17.65	70.6
2	2	Digi -Key	PWR221T-50-R 050J-ND	PWR221T-50-R0 50J	RES 0.05 OHM 5% 50W TO220	5.85	11.7
3	2	Digi -Key	696-1352-ND	PF2205-50RF1	RES 50 OHM 1% 50W TO220	4.2	8.4
4	2	Digi -Key	696-1346-ND	PF2205-2RF1	RES 2 OHM 1% 50W TO220	4.2	8.4
5	2	Digi -Key	TR50JBXR250- ND	TR50JBXR250	RES 0.25 OHM 5% 50W TO220	4.78	9.56
6	2	Digi -Key	VT3080S-E3/4 WGI-ND	VT3080S-E3/4W	DIODE SCHOTTKY 30A 80V TO-220AB	1.42	2.84
7	1	Digi -Key	696-1352-ND	PF2205-50RF1	RES 50 OHM 1% 50W TO220	4.2	4.2
8	1	Digi -Key	696-1346-ND	PF2205-2RF1	RES 2 OHM 1% 50W TO220	4.2	4.2
9	1	Digi -Key	TR50JBXR250- ND	TR50JBXR250	RES 0.25 OHM 5% 50W TO220	4.78	4.78
10	4	Digi key	696-1326-ND	PF2205-0R33F1	RES 0.33 OHM 1% 50W TO220	4.61	18.4 4
11	2	Digi key	TSM480P06CH X0G-ND	TSM480P06CH X0G	MOSFET P-CHANNEL 60V 20A TO251	2.28	4.56
12	3	Digi	VT3080S-E3/4	VT3080S-E3/4W	DIODE SCHOTTKY 30A 80V TO-220AB	1.42	4.26

		key	WGI-ND				
13	4	Mo user	926-LM7171AIM/NOPB	LM7171AIM/NOPB	Operational Amplifiers - Op Amps Hi-Spd Hi-Output V Feedback Amp	7.66	30.6 4
14	2	Mo user	227-TP65H050G4WS	TP65H050G4WS	MOSFET GAN FET 650V 34A TO247	13.70	27.4 0
15	2	Mo user	781-SUP90P06-09L-E3	SUP90P06-09L-E3	MOSFET 60V 90A 250W 9.3mohm @ 10V	4.68	9.36
16	2	Mo user	78-SQP100P06-9M3LGE3	SQP100P06-9m3L_GE3	MOSFET P Ch -60Vds 20Vgs AEC-Q101 Qualified	3.07	6.14
17	4	Digi key	696-1326-ND	PF2205-0R33F1	RES 0.33 OHM 1% 50W TO220	4.61	18.4 4
18	2	Digi key	TSM480P06CHX0G-ND	TSM480P06CHX0G	MOSFET P-CHANNEL 60V 20A TO251	2.28	4.56
19	3	Digi key	VT3080S-E3/4WGI-ND	VT3080S-E3/4W	DIODE SCHOTTKY 30A 80V TO-220AB	1.42	4.26
20	4	Mo user	926-LM7171AIM/NOPB	LM7171AIM/NOPB	Operational Amplifiers - Op Amps Hi-Spd Hi-Output V Feedback Amp	7.66	30.6 4
21	2	Mo user	227-TP65H050G4WS	TP65H050G4WS	MOSFET GAN FET 650V 34A TO247	13.7	27.4
22	2	Mo user	781-SUP90P06-09L-E3	SUP90P06-09L-E3	MOSFET 60V 90A 250W 9.3mohm @ 10V	4.68	9.36
23	2	Mo user	78-SQP100P06-9M3LGE3	SQP100P06-9m3L_GE3	MOSFET P Ch -60Vds 20Vgs AEC-Q101 Qualified	3.07	6.14
24	7	Digi key	A101972-ND	1-1337445-0	CONN BNC JACK STR 50 OHM PCB	4.56	31.9 2
25	4	Digi key	LM7171BIN/NOPB-ND	LM7171BIN/NOPB	IC VOLTAGE FEEDBACK 1 CIRC 8DIP	4.31	17.2 4
26	2	Digi key	VT3080S-E3/4WGI-ND	VT3080S-E3/4W	DIODE SCHOTTKY 30A 80V TO-220AB	1.42	2.84
27	4	Digi key	696-1346-ND	PF2205-2RF1	RES 2 OHM 1% 50W TO220	4.61	18.4 4
28	2	Digi key	696-1352-ND	PF2205-50RF1	RES 50 OHM 1% 50W TO220	4.61	9.22
29	3	Digi key	TSM480P06CHX0G-ND	TSM480P06CHX0G	MOSFET P-CHANNEL 60V 20A TO251	2.28	6.84
30	4	Digi key	PWR221T-50-R500F-ND	PWR221T-50-R500F	RES 0.5 OHM 1% 50W TO220-2	5.07	20.2 8
31	4	Digi key	732-744340300030CT-ND		FIXED IND 30NH 27A 0.27 MOHM SMD	2.07	8.28
32	4	Digi	TR50JBXR250-	TR50JBXR250	RES 0.25 OHM 5% 50W TO220	4.78	19.1

		key	ND				2
33	5	Digi key	1N5363BGOS-ND	1N5363BG	DIODE ZENER 30V 5W AXIAL	0.47	2.35
34	5	Digi key	1N4751AFS-ND	1N4751A	DIODE ZENER 30V 1W DO41	0.3	1.5
35	5	Digi key	1N5378BRLGO SCT-ND	1N5378BRLG	DIODE ZENER 100V 5W AXIAL	0.49	2.45
36	5	Digi key	1N5245BFSC-ND	1N5245BTR	DIODE ZENER 15V 500MW DO35	0.16	0.8
37	5	Digi key	1N5262BVSCT-ND	1N5262B-TR	DIODE ZENER 51V 500MW DO35	0.19	0.95
38	5	Digi key	1N5942BRLGO SCT-ND	1N5942BRLG	DIODE ZENER 51V 3W AXIAL	0.41	2.05
39	5	Digi key	1N5374BGOS-ND	1N5374BG	DIODE ZENER 75V 5W AXIAL	0.43	2.15
40	5	Digi key	1N4148FS-ND	1N4148	DIODE GEN PURP 100V 200MA DO35	0.1	0.5
41	5	Digi key	APT30D20BG-ND	APT30D20BG	DIODE GEN PURP 200V 30A TO247	2.95	14.7 5